

HALOGUARD™ II/IR

MULTI-GAS MULTI-SENSOR MONITOR

INSTRUCTION MANUAL



SERIAL NO. _____

MODEL NO. - - - +

Temp. Range

- 1 - = > 60°F
- 2 - = 40 - 60°F
- 3 - = < 40°F

No. of Sensors/Gas Type

- A - R-11
- B - R-12
- C - R-22
- D - R-134a
- E - R-113
- F - NH₃
- G - R-123
- H - Oxygen

Outputs

- 1 - 4 x 3A Relays
- 2 - 4 x 0 - 5 VDC
- or 0 - 10 VDC

Options/Accessories

- A - Audible Alarm
- B - UPS
- C - Auto Calibration
- E - Inlet/Exhaust Extension
- L - Strobe Light
- T - TWA Integration

THERMAL GAS *Systems* inc.

11285 Elkins Road Bldg. H-1
 Roswell, GA 30077
 TEL: 770-667-3865
 FAX: 770-667-3857
 www.thermalgas.com

IMPORTANT
READ ENTIRE BOOKLET BEFORE
INSTALLING OR OPERATING
HALOGUARD™ II/IR MONITOR

TABLE OF CONTENTS

	<u>Page</u>
1. Unpacking Instructions	3
2. Before Installation	3
3. Installation	6
a. Standard Cable Installation	6
b. Extended Cable Installation	7
4. Calibration	9
5. Testing	10
6. Trouble Shooting	10
7. Specifications	11

FIGURES

	<u>Page</u>
1. Dimension Drawing	4
2. Haloguard® II/IR Controller Upper Circuit Board	5
3. Haloguard® II/IR Controller Lower Circuit Board	5
4. Relay Junction Box Connections	5
5. LCD Display Features	5
6. Sensor Cable Terminal Connectors	6
7. IR Module Circuit Board	7
8. Alarm Jumper Settings	8
9. Exposure Limits	8
10. Function Jumper Settings	8
11. Initial Factory Settings	11
12. Wiring Diagram	12

UNPACKING INSTRUCTIONS

Haloguard[®] monitors are carefully packed, inspected and delivered to the carrier in good condition. If damage occurs in transit it is the responsibility of the carrier.

Carefully inspect the unit upon receipt. Any damage should be reported to the carrier and an inspection requested. After inspection by the carrier and your receipt of his acknowledgment as to the damage, contact us for return authorization (RMA). We cannot file claims for damaged goods on your behalf, but we will assist you in any way we can.

In order to expedite our work, please provide serial number and purchase date when you call.

WE CANNOT ACCEPT RETURNS WITHOUT PRIOR APPROVAL.

BEFORE INSTALLATION

1. Remove Haloguard[®] II/IR Controller and IR Sensor Module from carton. Check contents against packing list. If shipment is incomplete, contact us immediately.
2. The following tools and hardware are required for installation and calibration.
 - a. Two standard screwdrivers; 1-medium, 1-jewelers fine. One phillips - medium.
 - b. Needle-nosed electrician's pliers
 - c. 9/32" Nut driver
 - d. (7) No. 10 x 1" Screw -
 - e. Digital VOM
3. Select the site for installation:
 - a. Power requirements: Provide a clean source of 115-230 VAC, 50/60 Hz, single phase circuit rated 15A minimum for both Haloguard[®] II/IR Controller and IR Sensor Module.
 - b. IR Sensor Module should be mounted near potential leaks in a quiet area or downstream from leak source in area with air movement.
 - c. IR Sensor Module sample tube should be mounted 18" - 24" above the floor. Install Inlet/Exhaust Extension Tube(Optional) for remote sample location (up to 200 FT). Make sure each sample tube is equipped with an end of line filter.
 - d. Make sure the area selected is not subject to flooding, potential impact or severe ambient temperature and humidity changes (i.e. boiler blow-down or near roll-up doors).
 - e. Infrared detector is highly selective but may respond to presence of some gases (i.e. paint thinner, cleaning fluids and other refrigerants), if interfering gas reaches a high concentration. For accurate refrigerant leak detection select a location free from above fumes or temporarily disable sensor when they are present. Contact TGS for specific interferences.
4. The wall-mounted controller should be installed indoors, approximately five feet above the floor or at a location easily visible to operators, in an area with minimal vibration, and with temperature and humidity changes like sensor location.

IMPORTANT

CONSULT LOCAL AND NATIONAL ELECTRICAL CODES FOR ANY SPECIAL REQUIREMENTS OR RESTRICTIONS BEFORE INSTALLING HALOGUARD[®].

5. LED Indicators, Pushbuttons, LCD Display, and Relays

- a. AUTO/MAN Push-button - In the AUTO mode, the Haloguard® II/IR controller automatically scans all active channels in sequence. Manual mode is initiated by pushing the MAN push-button. In the MAN mode, monitor remains locked on a single channel until manually sequenced to another channel by pushing MAN push-button. After 2 minutes, sequencer will automatically default to AUTO mode.
- b. TEST Push-button -When depressed alarm relays, lights, audible and remote devices (if equipped) will activate. Analog outputs will go full scale
- c. OFFSCALE LED and Relay - Factory set at 1000ppm (See Figure 11).
- d. HI Alarm LED/LO Alarm LED and Relays - User adjustable 10ppm to 1000ppm (See Figure 8).
Note: Optional TWA Integration activates LOW Alarm LED and relay.
- e. FAULT LED and Relay - Indicates malfunction at IR Module, LCD indicates specific type of failure (See Figure 5).
- f. POWER LED indicates Haloguard® II Controller is receiving power.
- g. RESET Pushbutton and LED - Indicates Haloguard® in 20 minute RESET mode. During RESET mode all alarm relays, audible and visual alarms are disabled. Alarms are automatically enabled if alarm condition is not corrected in 20 minutes. Reset is automatically initiated on power up.

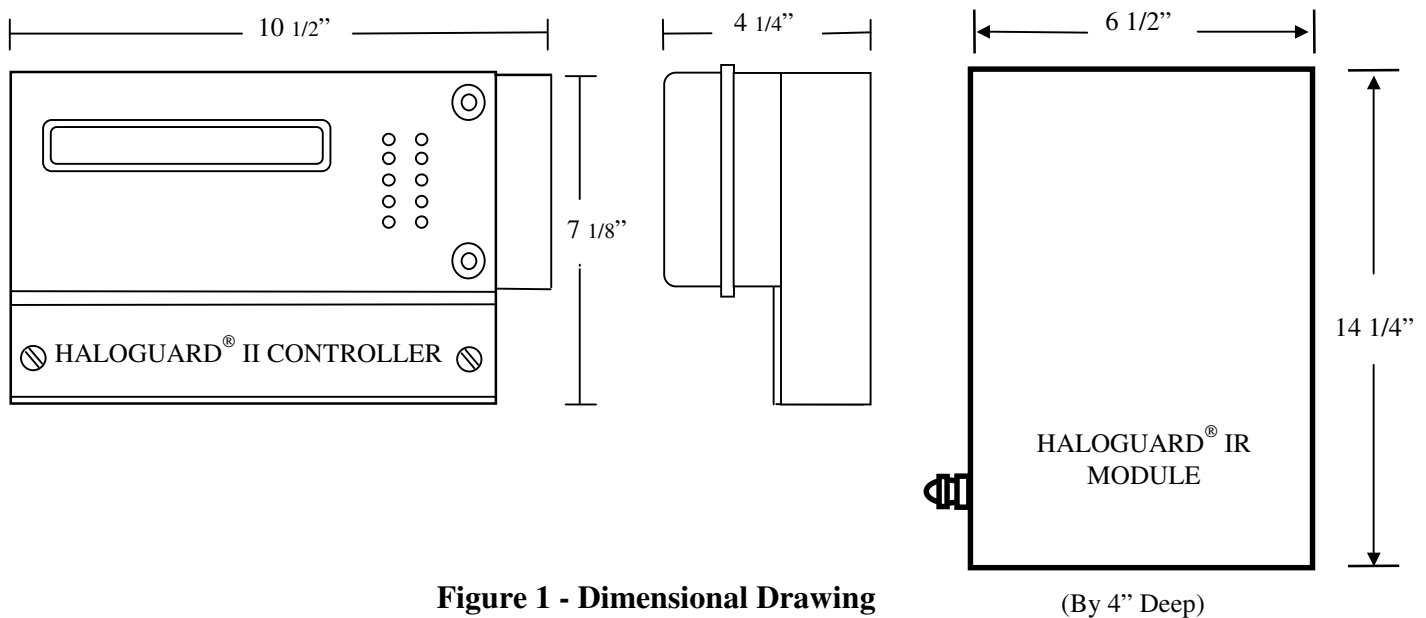

Figure 1 - Dimensional Drawing

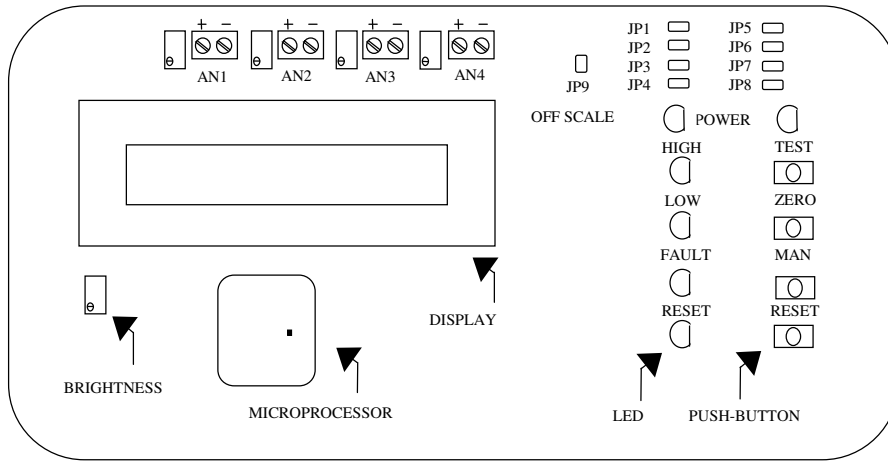

Fig 2 - Haloguard II/IR Controller Upper Circuit Board

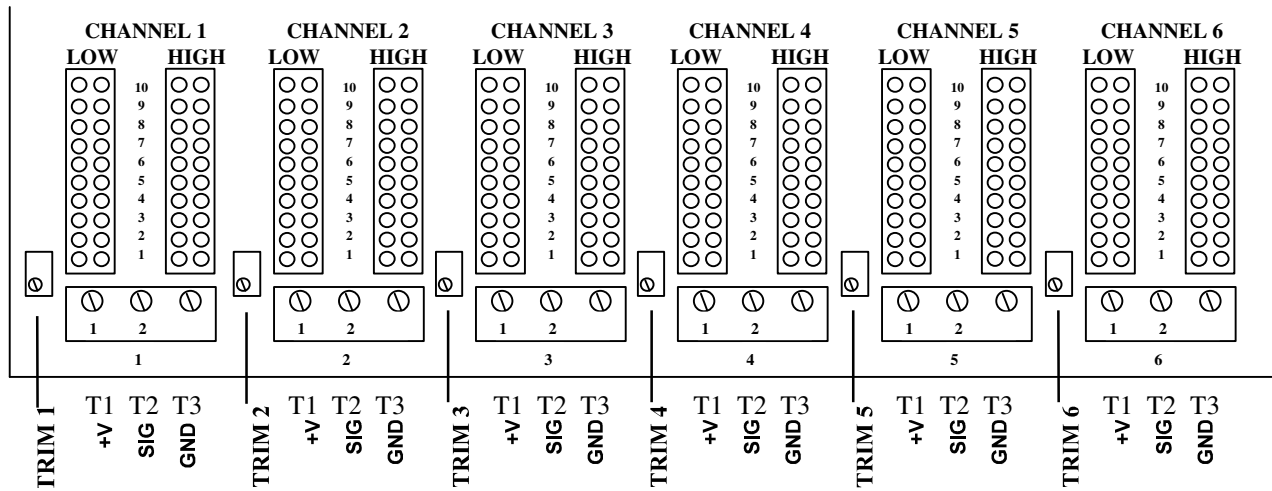

Figure 3 - Haloguard II/IR Controller Lower Circuit Board

OFF SCALE	1	○	NC
	2	○	COM
	3	○	NO
HI ALARM	4	○	NC
	5	○	COM
	6	○	NO
LO ALARM	7	○	NC
	8	○	COM
	9	○	NO
FAULT	10	○	NC
	11	○	COM
	12	○	NO

Figure 4 - Relay Junction Box

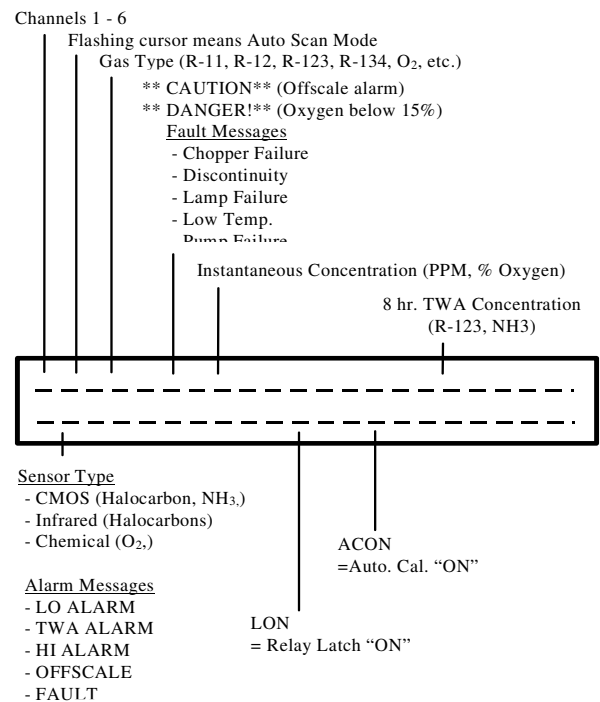

Figure 5 - LCD Display Features

INSTALLATION

1. Check power supply. (See Section “Before Installation 3a”)
2. Disconnect power before beginning.
3. Mounting Instructions
 - a. To mount Haloguard® II/IR controller:
 1. Install No. 10 x 1” screw at approximate center of desired location. Slip controller over fastener head.
 2. Remove lower cover to expose lower circuit board. Install two additional fasteners through holes provided beneath lower cover.
 - b. To mount IR Sensor Module
 1. Mount IR Module in a **VERTICAL** position in a location not subject to vibration or extreme temperature fluctuation. Remove cover. Secure with No. 8 x 1” (min.) screws through (4) holes beneath cover or use mounting feet provided. Extend sample tubing to 18-24” above floor, terminate with end of line filter.
 2. Inlet/Exhaust Extension (optional) may be used to extend sample point up to 200FT with 0.125”OD x 0.093”ID nylon, copper, or stainless steel tubing. When extending tubing:
 - a. Keep sample lines as short as possible and free of kinks.
 - b. Attach 30 micron Inlet Filter at sample point.
 - c. Exhaust to atmosphere. **DO NOT** install any device which might restrict the flow.

Refer to FIGURE 3 - Controller Lower Circuit Board before proceeding.

DO NOT CUT SUPPLIED CABLE

Maximum Extension length 1000 Feet.

4. Connecting Haloguard® II/IR Controller and IR Sensor Module
 - a. **Wiring Instructions using supplied cable without extension:**
 1. Eight feet (8FT.) of cable with DIN connectors is supplied. Connect cable from Haloguard® II/IR Controller to IR Sensor Module location

Refer to Figures 2 and 3 before proceeding.

- b. **Wiring Instructions using cable with extension:**
 1. We recommend 3 conductor 18 ga. cable with foil shield, Carol C0455 or equal. Use 3/4” conduit if required.
 2. Haloguard® II/IR Controller is provided with 18” cable with DIN Connector and IR module is provided with 6 1/2’ cable. To extend sensor beyond the provided length, remove 18” cable with DIN connector from controller Lower Circuit Board. Splice or solder extension cable to end of 18” cable. Reconnect extended sensor cable to terminal block in lower circuit board of controller.

Terminal	Provided Wire Color	Extension Wire Color	Function
T1	Red	Red	See Note
T2	White	White	Signal
T3	Blk./Blk	Black/Shield	Ground

Note: T1 Used with Oxygen Sensors Only.

Figure 6 - Sensor Cable Terminal Connection

Refer to Figure 4 before proceeding.

5. Remove junction box cover.
 - a. Relay Terminals - Connect alarm relays (NO or NC) as required.

Remove Alarm Set point Jumpers from all active channels and JP-9 (If Optional Audible Alarm and/or Strobe are supplied.) before continuing set-up.

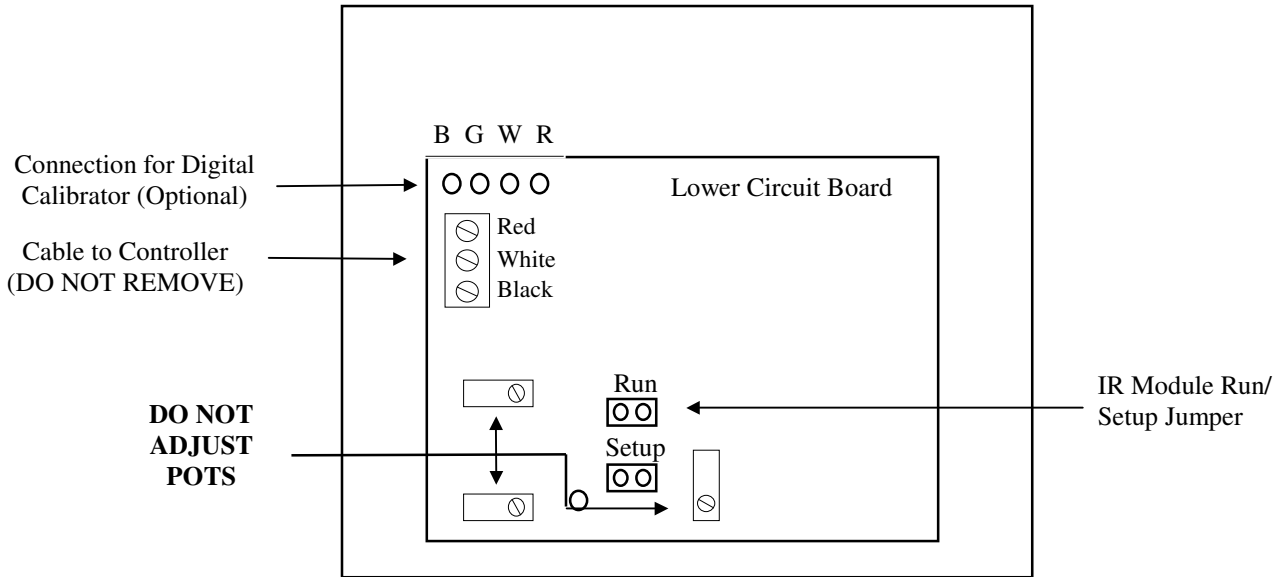

Figure 7 - IR Module Circuit Board

6. Calibrate with a digital VOM as follows:
 - a. Remove cover(s) on IR Sensor Module(s). Move Jumper(s) from RUN to SETUP (See Figure 7). **Wait approximately 1 minute before proceeding.**
 - b. Remove lower cover and faceplate on the Haloguard[®] II/IR Controller.
 - c. With VOM on 5 VDC scale, place probes on T2 - SIG (+) and T3 -GND (-) (See Figure 3 - Controller Lower Circuit Board).
Select MAN mode with push-button, sequence to first channel. **Adjust potentiometer to the left of each screw terminal with screwdriver until it reads 4.975 VDC.**

**THIS SET-UP MUST BE COMPLETED FOR EACH IR MODULE
(1 thru 6)**

Sequence to subsequent active channels using MAN push button and follow same procedure for each IR module.

Haloguard[®] II/IR Controller automatically returns to scanning mode after 2 minutes or press TEST button to start scanning.

- d. Replace IR Module jumper(s) in "RUN" mode.
 - e. Replace Audible Alarm jumper JP-9 in Haloguard[®] II/IR Controller, to re-activate audible alarm circuit.
7. Alarm Set point Adjustment - (See Figure 3 - Lower Circuit Board) Place jumper on appropriate alarm point to initiate visual or audible alarms and relays.

Alarm	Low	High
Jumper	ppm	ppm
10	500	1000
9	450	950
8	400	900
7	350	850
6	300	800
5	250	750
4	200	700
3	150	650
2	100	600
1	50	550

Figure 8 - Alarm Jumper Settings

Notes:

Oxygen alarms are preprogrammed at 19.5% (LO) and 16% (HI);

For optional TWA Integration, LO alarm is pre-programmed to the TLV-TWA for specified gas.

GAS	TLV-TWA*	CEIL	PEL
R-11	•	1000	•
R-12	1000	•	1000
R-22	1000	•	1000
R-123	50	•	•
R-134a	1000	•	1000
R-500	1000	•	1000
R-502	1000	•	•

Other exposure limits are pending.

TLV-TWA = 8hr./day, 40hr./wk. avg. Short term exposures should not exceed 3 - 5 times the TWA for more than 30 min./day.

* ACGIH Trademark.

Figure 9 - Exposure Limits

Refer to Figure 2 before proceeding.

8. Locate SETUP jumpers JP-1 thru 9 on Upper Circuit Board (Figure 2). Select required settings from the following menu:

JP	HALOGUARD® II/IR CONTROLLER FUNCTIONS
JP-1	In house ONLY .
JP-2	Optional Autocalibration (See 7a)
JP-3	Set scan rate, 0-10 sec. adjustable (See 7b)
JP-4	Set gas type and channel (See 7c)
JP-5	In House ONLY . System set-up info.
JP-6	Set clock, in house only)
JP-7	In house ONLY .
JP-8	Relay Latch (See 7e)
JP-9	Audible alarm and jumper storage. (See 7f)

Figure 10 - Function Jumper Settings

Use jumper from JP-9. After selecting from the above, the LCD will show a new mode (SETUP, etc.) and the MAN and ZERO pushbuttons will have new functions.

- Autocalibration** (Optional) select JP-2, LCD shows ACON. Haloguard® compares temp and RH every 4 hours to compensate for sensor drift. **DO NOT REMOVE JUMPER ON JP-2.**
- Scan Rate** - Rate is factory set at 4 sec. per active channel. To change, select JP-3, push ZERO and step to desired rate. Remove jumper from JP-3.

Refer to Figure 5 before proceeding

- c. **Channel and Gas Type** - See Figure 11 - Initial factory setting chart for channel set-up information. To change, select JP-4, push ZERO and sequence to channel (1 thru 6) desired, push MAN to initiate gas type menu, push ZERO and scroll to gas type desired (Note: NONE selected will skip channel). Press MAN to initiate sensor type menu, push ZERO to select sensor type. Proceed to next channel and follow same process. When finished, remove jumper from JP-4. This procedure is only used when adding/deleting or changing sensor or IR Modules
- d. **TWA Integration**, (Optional). Haloguard[®] calculates an 8 hr. TLV-TWA, displays this value on LCD, activates LO alarm LED and relay if preprogrammed PPM value is exceeded. (Must be powered up for 8 hrs. to build database before operating).
- e. **Relay Latch Setup** -Recommended factory setting is Unlatched Mode; the alarm LEDs and relays will return to a normal status when gas concentration goes below alarm set point. To select Latched Mode place jumper on JP-8. Latch mode requires manual RESET for all alarms. Press RESET button to release alarm (Note: Alarm will only be disengaged for 20 minutes unless condition is corrected).
- f. **Audible Alarm** -Jumper on JP-9 is factory installed to activate alarm circuit. To disable alarm remove JP-9 jumper.

****WARNING**ANALOG OUTPUT IS A DRIVEN SIGNAL, DO NOT CONNECT ANY WIRE WITH VOLTAGE OR CURRENT TO ANALOG OUTPUT TERMINALS**

- 9. **Analog Output** (Optional) - Connect Analog outputs AN 1 thru AN4 ((+) SIG and (-) GND if supplied) where indicated. (See Figure 12)
 - a. Trim optional analog outputs by pushing TEST button and turning potentiometers on AN 1 thru AN-4 (see Figure 2 - Upper Circuit Board) until output measures 5.0 or 10.0 VDC as required. Read warning on wiring diagram (Figure 12) regarding connection of analog output.
- 10. LCD display adjustment changes brightness of LCD - Adjust potentiometer (See Figure 2 - Upper Circuit Board) as required.
- 11. For 20 minutes after power up all alarm relays and alarms are automatically disabled. During this period, RESET LED will be lit. If power is disrupted, RESET mode will be automatic to protect against false alarms.

CALIBRATION

Haloguard II/IR monitors are factory calibrated to the gas of interest; field recalibration is not required for operation in typical machine room environments during the first twelve months of operation unless drift exceeds more than 5ppm in a 30 day period.

For those who wish to check the factory calibration an optional Digital Calibrator and Span Gas Kit is available. Instructions for use are included with kit

TESTING

The Haloguard[®] should be tested at start-up, after any changes to the alarm protocol, and after each alarm level condition has been corrected.

1. Alarm Test - Push and hold TEST button; alarm relays, lights, audible and remote alarm (if equipped) will activate. Analog outputs will go full scale.
2. Reset Test - Push RESET button; alarm relays, audible and remote alarms (if equipped) will become inactive for 20 minutes. RESET LED will be green.

TROUBLESHOOTING

The most frequent cause of nuisance alarms and faults is improper set-up, primarily due to:

1. Failure to install in accordance with instructions.
2. Not allowing sufficient warm-up time
3. Poor sensor location.

To check Zero calibration, fill a clean plastic trash bag with clean outside air, tie off with twist-tie, let sample stabilize inside for 15 - 20 minutes. Insert 1/8" OD sample tube into bag.

Allow 5 minutes for clean air sample analysis. Observe LCD response. If displayed PPM value drops then Haloguard II/IR is detecting the gas of interest or a gas that absorbs IR light at the same frequency. LCD should display "0 ppm". If LCD does not show "0 ppm", follow calibration procedure described in Section 6.c. on page 7.

Upon completion, remove tube from bag and observe LCD response. If PPM then moves higher, look for possible sources of interfering gases (See "Before Installation" section 3e). and relocate sensor.

We wish to help with any problems you might experience with the Haloguard[®] II/IR. When contacting our service department, please provided the following information.

1. Model Number and Serial Number.
2. Description of problem.
3. Remove faceplate and covers from Haloguard[®] II/IR Controller (Figures 2 and 3). Advise jumper and alarm positions.
4. Remove Relay Junction Box cover (Figure 4). Advise where Alarm wires are connected.
5. Using Figure 3 (Lower Circuit Board) as a guide, measure voltage between T2 (SIG) and T3 (GND), for all IR modules. Write down values.
6. Using LCD Display (Figure 5) as a guide, observe the LCD as it scrolls. Write down all information displayed.
7. Advise the condition of all LED's on the faceplate.

SPECIFICATIONS

Technology:	Infrared Photoacoustic	Response Time:	< 1 Minute per sample point
	Oxygen - Electro Chemical	Operating Conditions:	
Electrical Supply:	115-230 VAC, 50-60Hz	IR Module	+40°F to +120°F Non-condensing
		O ₂ Sensor	+40°F to +110°F Non-condensing
Output Signal:	Std. 4 x 3A Dry Contact Relays (NO or NC)	Controller	0°F to +120°F Non-condensing
	Opt. 4 x 0 - 5 VDC Analog	Fault Diagnostics:	Indicator Light or LCD Readout for fault diagnostics (See Fig.. 5)
Alarm Outputs:	Three Level Contact Closure	Materials:	
Readout:	Digital Meter, Displayed in PPM Gas Type, Range and options.	IR Module	NEMA 4/12/13 Design
		Controller	NEMA 12/13, IP65 Design
		Oxygen Sensor	PVC and porous PP
Display Accuracy:	1 ppm 0 - 100 ppm Range (IR)	Weight:	
	10 ppm 100 - 1000 ppm Range (IR)	IR Module	10 lbs.
		Controller:	4 lbs. (Add 2 lbs. optional battery)
	1% Electrochemical (Oxygen)	Dimensions:	
Ranges:	0 - 1000 ppm R11, R12, R22, R134a, R113, and R123,	IR Module	6-1/2" W x 14-1/4" H x 4" D
	0 - 25% Oxygen	Controller	10-1/2" W x 7-1/8" H x 4-1/4"D

Initial factory settings are:

Channel	1	2	3	4	5	6
Calibration Gas						
Sensor Type						
Lo Alarm						
Hi Alarm						
Full Scale PPM						
TWA Alarm Level						

Figure 11 - Initial Factory Settings