

# HALOGUARD® III

Cost-effective Photoacoustic Infrared Refrigerant Monitoring for Wide Area Applications



Complete Submittal  
Information online:  
[www.thermalgas.com](http://www.thermalgas.com)

**Photoacoustic Infrared  
Technology Enhances  
Selectivity & Sensitivity for:**

- Refrigeration Equipment
- Machinery Rooms
- Cold Storage Areas
- Process Cooling

- Provides low ppm detection for all refrigerants. Optionally reports oxygen depletion.
- Meets ANSI/ASHRAE Standard 15, and all Mechanical, Fire & Building codes
- Single or multigas
- Single or multipoint sensing
- Alerts service personnel
- Features remote notification
- Upgradeable to newer refrigerants
- Reduces refrigerant loss
- Controls exposure risk

**THERMAL GAS *Systems* inc.**  
Haloguard® Monitors

# HALOGUARD® III

## Cost-effective, 20 ppm Photoacoustic Infrared 24 Hour Refrigerant Leak Detection & Notification

The HALOGUARD® III combines advanced microprocessor based digital signal processing and a wideband photoacoustic infrared cell to provide the newest most advanced system for continuous monitoring of all refrigerant gases.

The HALOGUARD® III monitors single or multiple, local and remote locations and provides notification when gas concentration reaches preset alarm levels. Up to 24 different gases may be monitored simultaneously by adding optional channel scanners and remote IR modules.

Alarm relays and analog outputs are designed to activate remote devices or to interface with an energy management (EMS) or building automation (BAS) system.

To find out more, contact Thermal Gas Systems today.

### Features

- Detects all refrigerants & heat transfer fluids
- Simple installation
- Factory calibrated & programmed
- Up to 500 ft. sample draw
- Six user alarms adjustable between 50 ppm & 100% of scale
- LCD shows PPM Concentration, Alarm, Test, Reset, and Fault Diagnostics
- Three flashing alarm LED's
- Fault, Ready & Power ON/OFF LED's
- Seven alarm relays for ventilation, damper or remote notification
- Alarm Test & Reset/Silence push buttons
- High-intensity audible alarm
- Rugged enclosure

### Options

- 2, 4 or 8 channel scanner
- Analog output for BAS/EMS interface or data logging
- Remote IR sensor modules allow up to 24 sensing points
- Amber strobe light alarm
- Remote strobe light & horn alarms
- Gas calibration kit
- NEMA 4 enclosure
- Oxygen depletion sensor

### Specifications

Technology.....	Photoacoustic infrared
Electrical Supply .....	100-240V, 50-60Hz, 65W
Fuse .....	3A/240V, fast acting
Output Signal	Std: 7 x 10A, dry contact SPDT relays Opt: 0-5,10 VDC, 4-20mA analog Opt: RS232 serial com
Sensitivity.....	20 ppm
Resolution.....	1 ppm
Measuring Range.....	0 - 1000 ppm all refrigerants
Response Time.....	<1 minute per channel
Clearing Time .....	<2 minutes per channel
Maximum Sample Point	
Tubing Length.....	150' with standard performance. 500' optional where slower response is acceptable.
Operating Conditions .....	30°F to +120°F (0°C to +50°C), non-condensing
Enclosure:	Weight:
Std: NEMA 12 .....	24 lbs
Opt: NEMA 4 .....	28 lbs
Sample Rate .....	1.5 Lpm in free air

Electrical Safety Conforms to UL/CSA/EN 61010-1  
Electromagnetic Compatability Conforms to FCC Part 15 B, ICES-003:ISSUE 5, ANSI C63.4:2009 and EN 61326-1



### Warranty

HALOGUARD® III is guaranteed for 18 months from the date of shipment. Any device found defective in that period will be repaired or replaced free of charge. Read terms and conditions of sale for complete warranty information.

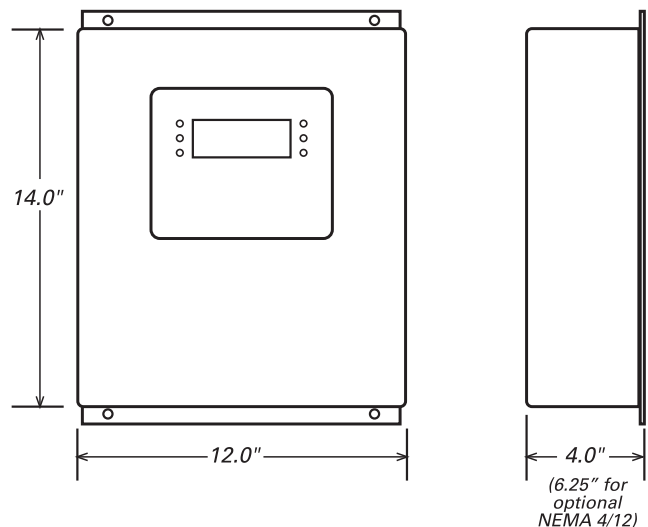

**THERMAL GAS *Systems* inc.**

11285 Elkins Road, Bldg #H-1 • Roswell, GA 30076 USA

Tel: (770) 667-3865 • Fax: (770) 667-3857

www.thermalgas.com